

Deep Dive on Ebola: what if infectivity increases over time?

Emma McBryde

University of Melbourne

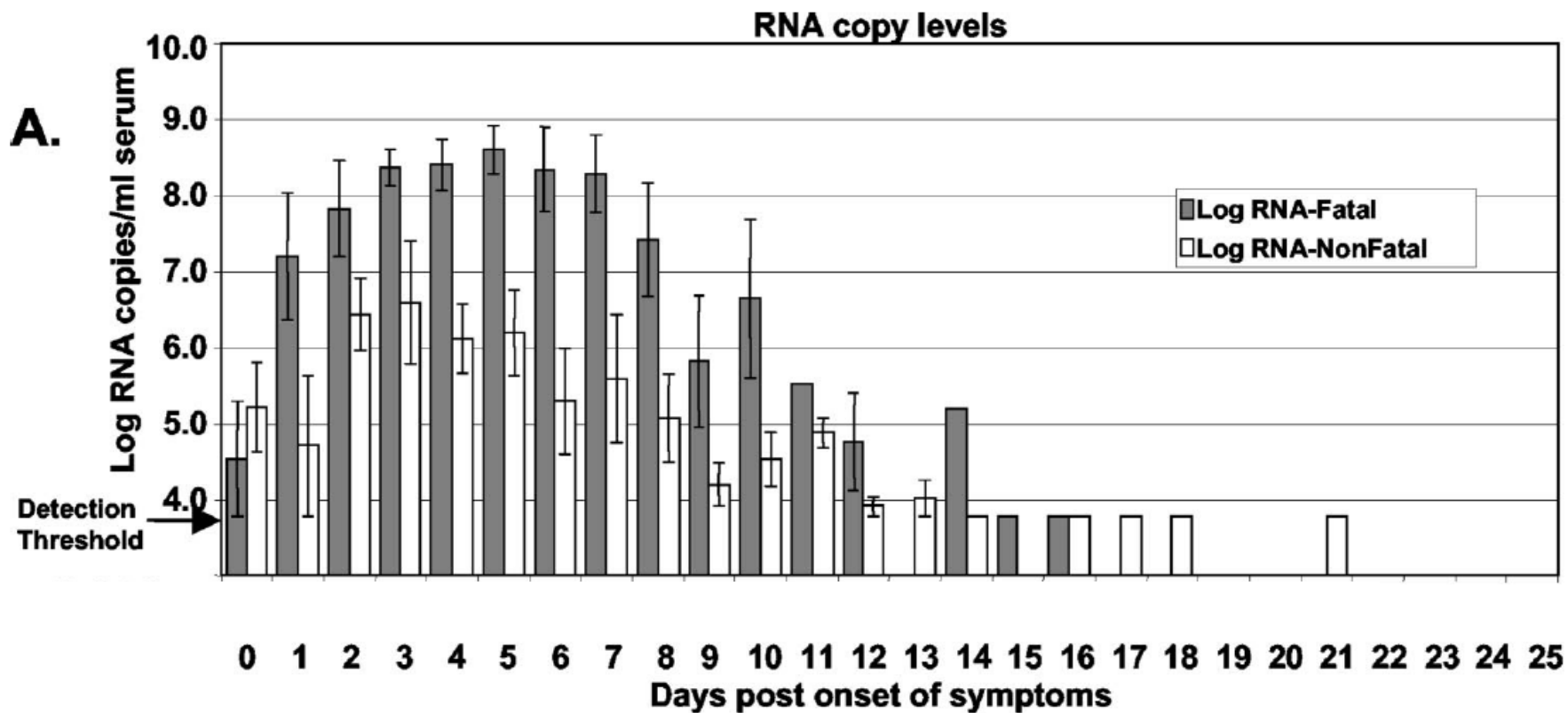

Model

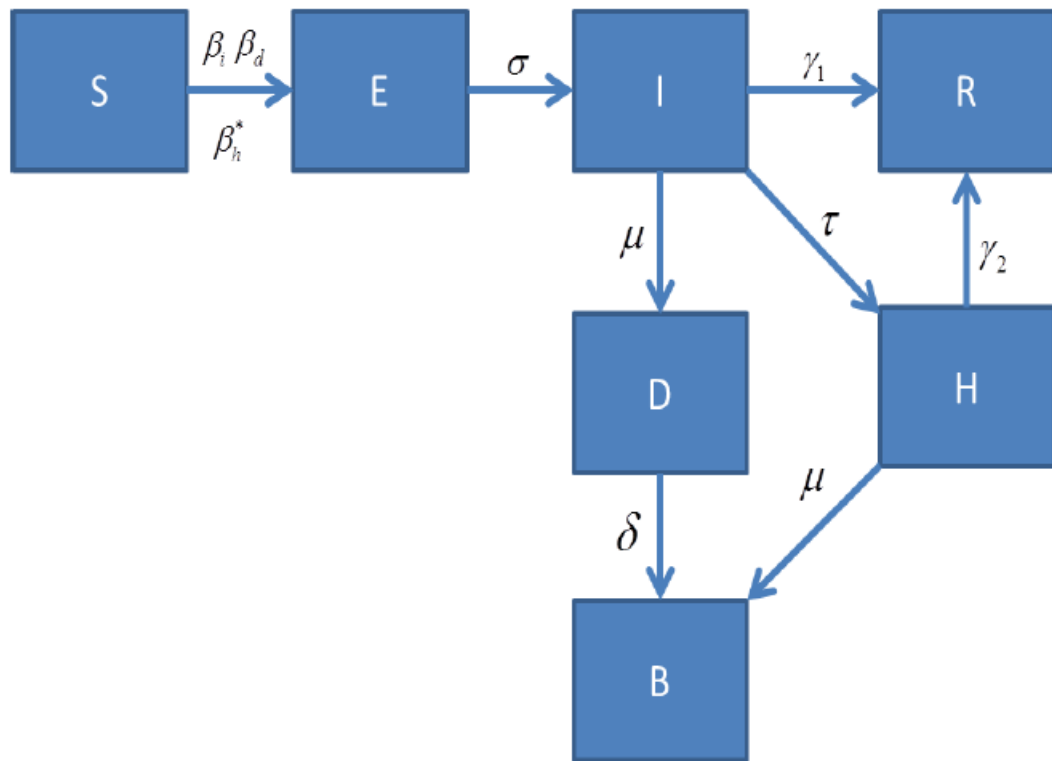

$$R_0 = \frac{\beta_i + \beta_d \frac{\mu}{\delta} + \beta_h^* \frac{\tau}{\mu + \gamma_2}}{\mu + \tau + \gamma_1}$$

$$\frac{dS}{dt} = -\beta_i SI - \beta_h^* SH - \beta_d SD$$

$$\frac{dE}{dt} = \beta_i SI + \beta_h^* SH + \beta_d SD - \sigma E$$

$$\frac{dI}{dt} = \sigma E - (\gamma_1 + \mu + \tau) I$$

$$\frac{dR}{dt} = \gamma_1 I + \gamma_2 H$$

$$\frac{dD}{dt} = \mu I - \delta D$$

$$\frac{dH}{dt} = \tau I - (\gamma_2 + \mu) H$$

Model with differences in infectiousness

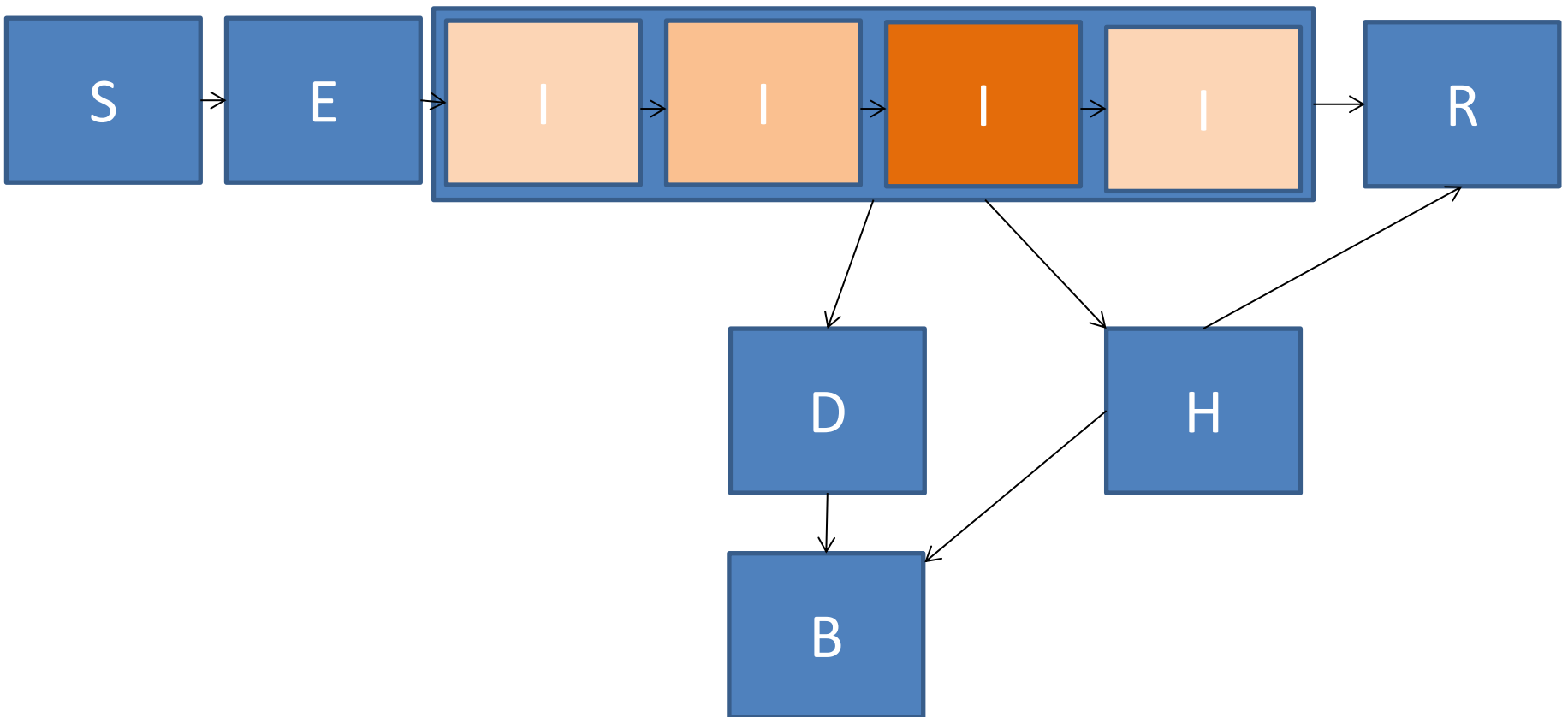

Additional parameters	Meaning	Value (per day)
τ_i	Transition between Infectious compartments	1/2.8
β_{i1}	Infectiousness in I_1	0.17
β_{i2}	Infectiousness in I_2	0.28
β_{i3}	Infectiousness in I_3	0.85
β_{i4}	Infectiousness in I_4	0.17

Additional model constructs

- Hospitalisation Death & Recovery at same rate for all infectious compartments [I_1, I_2, I_3, I_4] like the one-compartment model
- Also examined a 4 compartment model with constant infectiousness

Expected new infections over time

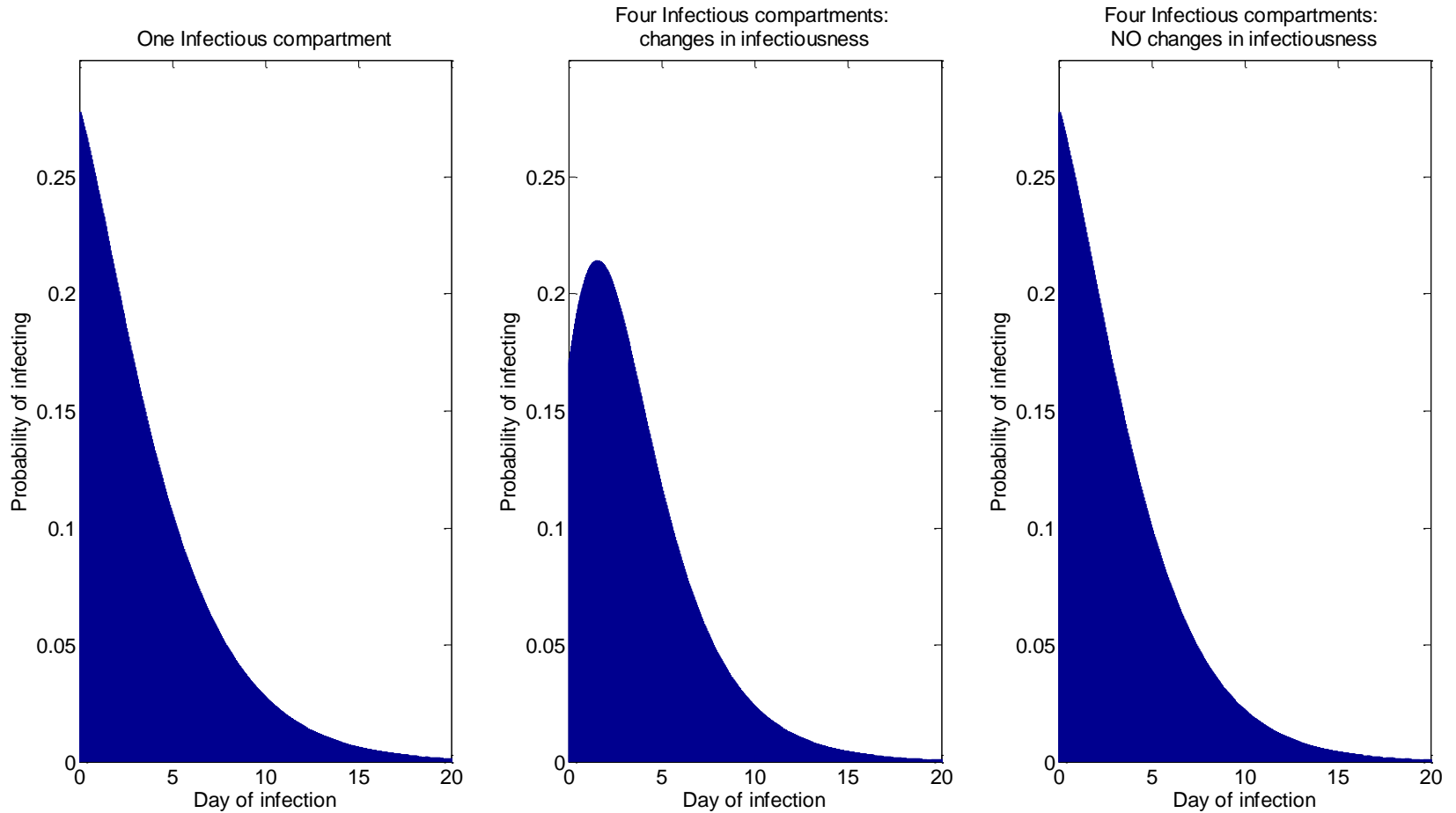

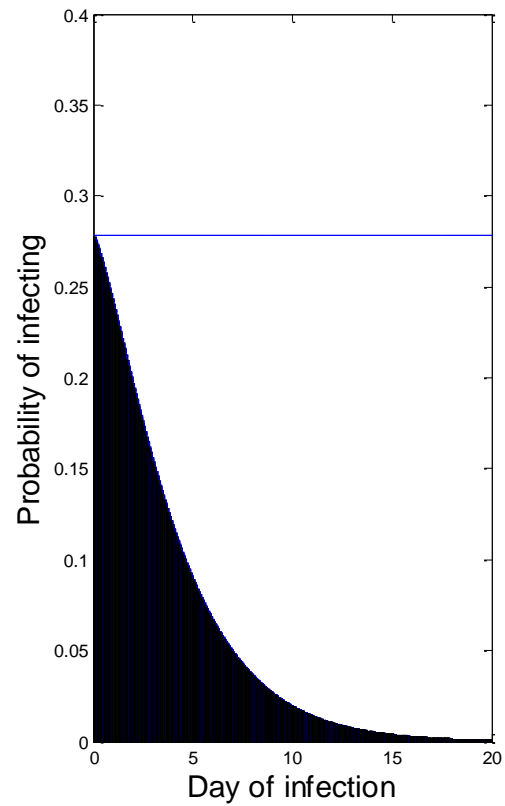
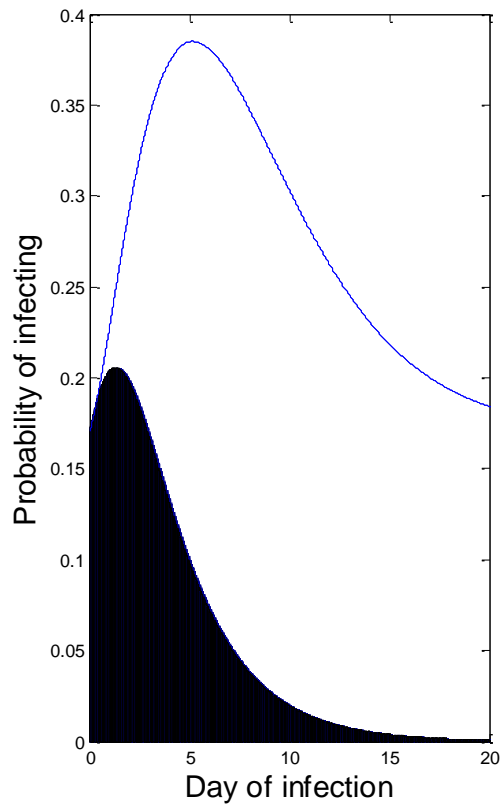
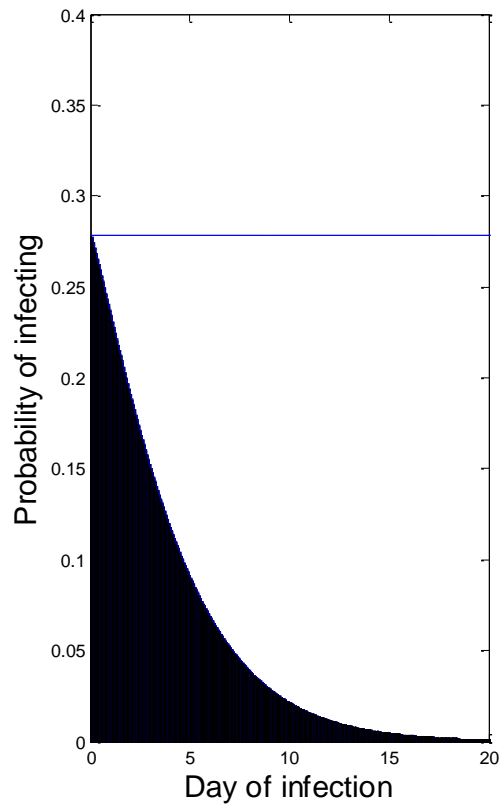

Intervention: Home quarantine

Model	Proportion of infectious people home quarantined	R_{eff}	Expected Time in community and infectious
One I compartment	0 %	1.32	2.56
Four Infectious compartments Time varying infectiousness	0 %	1.32	2.56
Four Infectious compartments Invariant infectiousness	0 %	1.32	2.56

Calibration

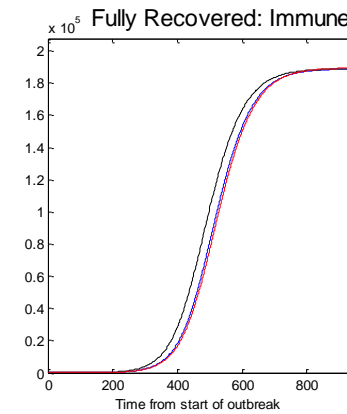
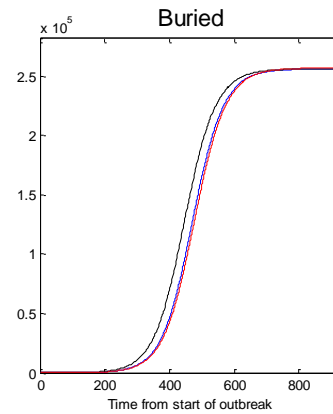
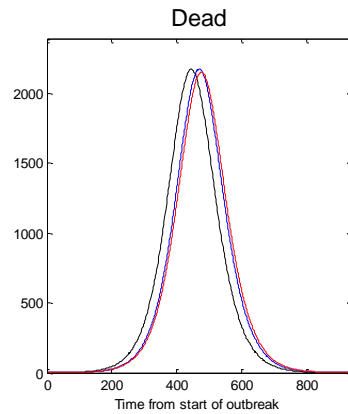
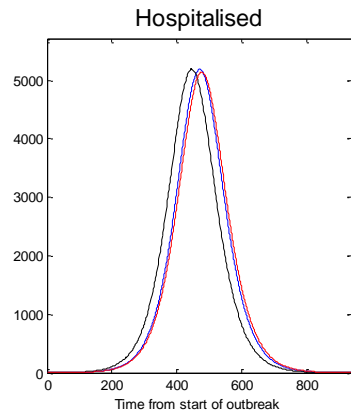
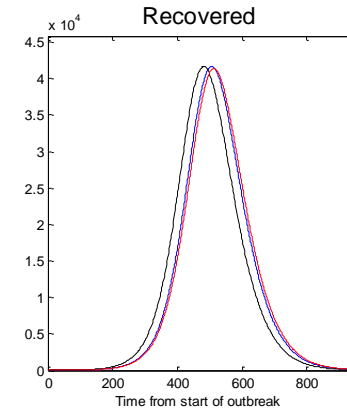
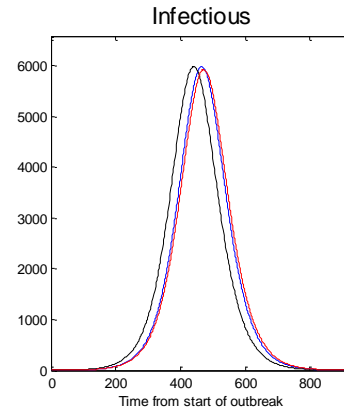
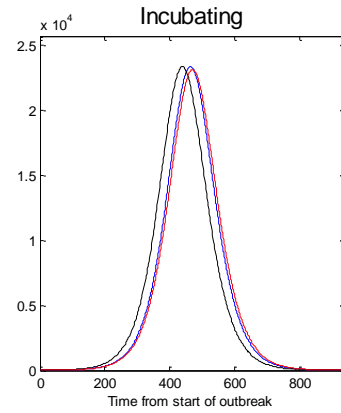
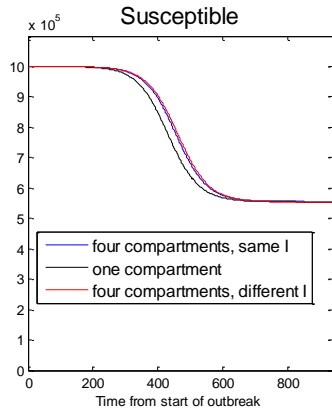

Intervention: Home quarantine

Model	Application	Rate	Proportion of infectious people quarantined	R_{eff}	Expected Time in community and infectious
One I compartment	To all I	0.05	8.9%	1.17	2.27
4 I compartments Time varying infectiousness	I2, I3, I4	0.12	8.9%	1.14	2.27
4 I compartments Invariant infectiousness	I2, I3, I4	0.12	8.9%	1.17	2.27

Individual level impact of home quarantine on infectiousness

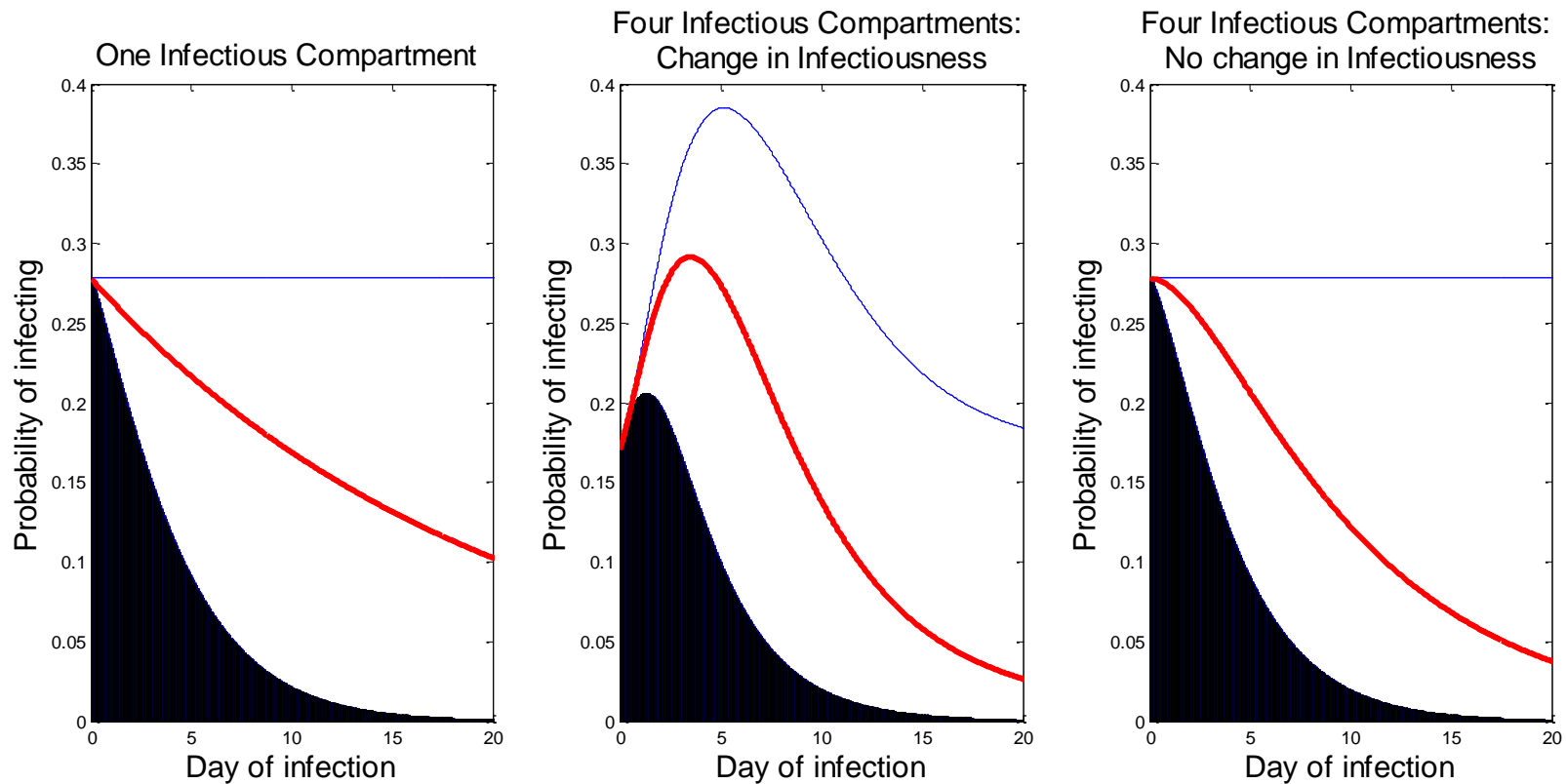

Impact on Epidemic of home quarantine: different infectiousness models

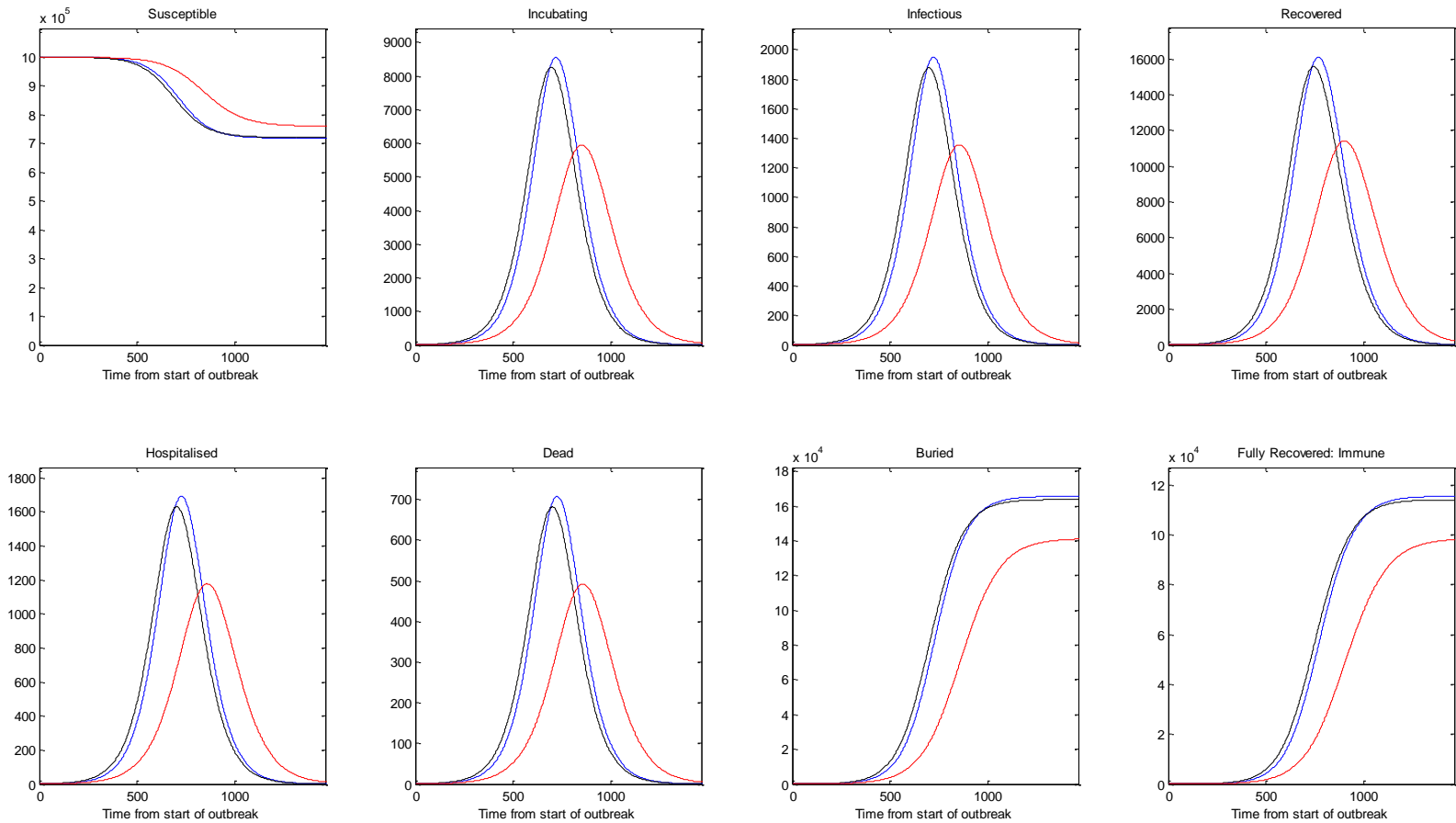

Take home messages

- The model results are very sensitive to assumptions around interventions on duration in the infectious compartment
- Sensitivity extends to assumptions about shape of infectiousness and shape of interventions
- These may need to be considered when thinking of interventions like home quarantine