

SoMoX – The SOfware MOdel eXtractor

Reverse Engineering Component-Based Architectures from Source Code
Klaus Krogmann

SOFTWARE DESIGN AND QUALITY GROUP



What SoMoX does

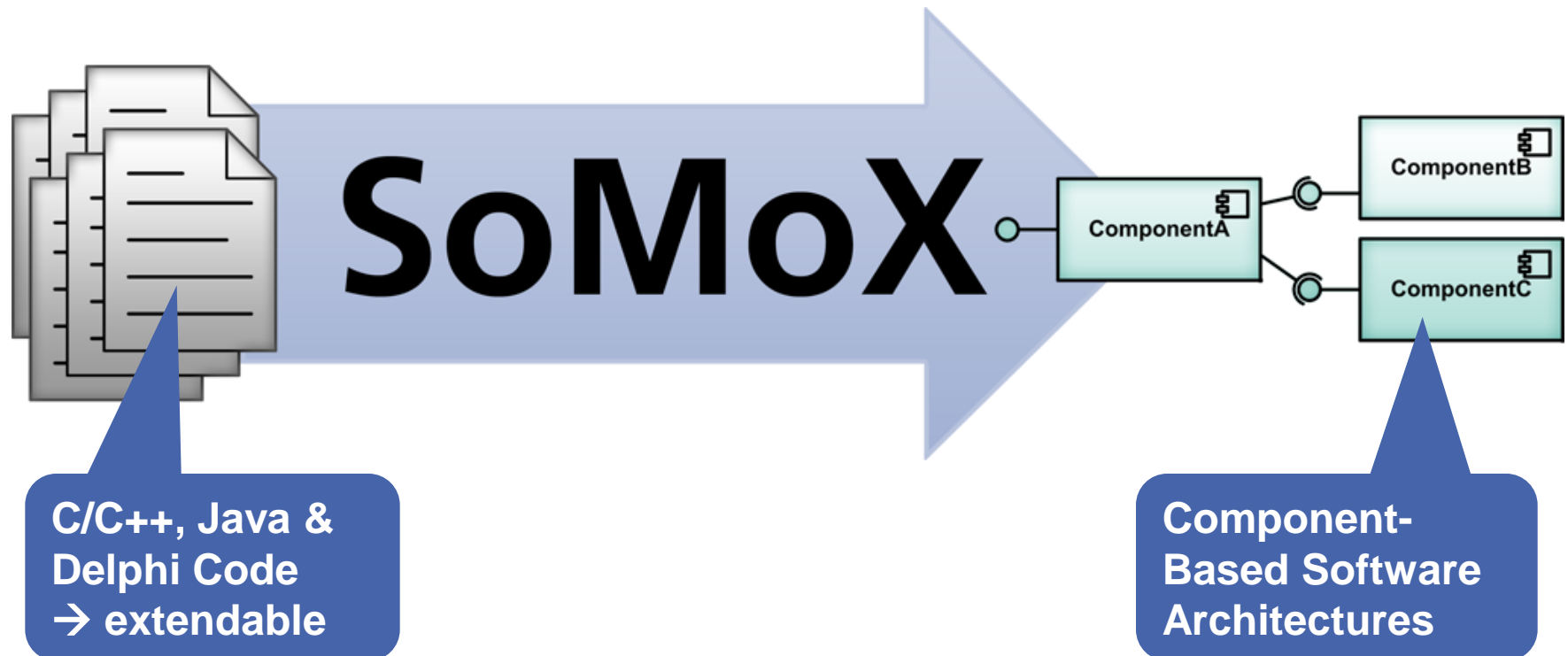

What is Recognized?

- Components
 - Boundaries
 - Their related classes
 - Composite Components
- Interfaces
- Connectors
- Additionally: Trace Model
 - Behaviour Model

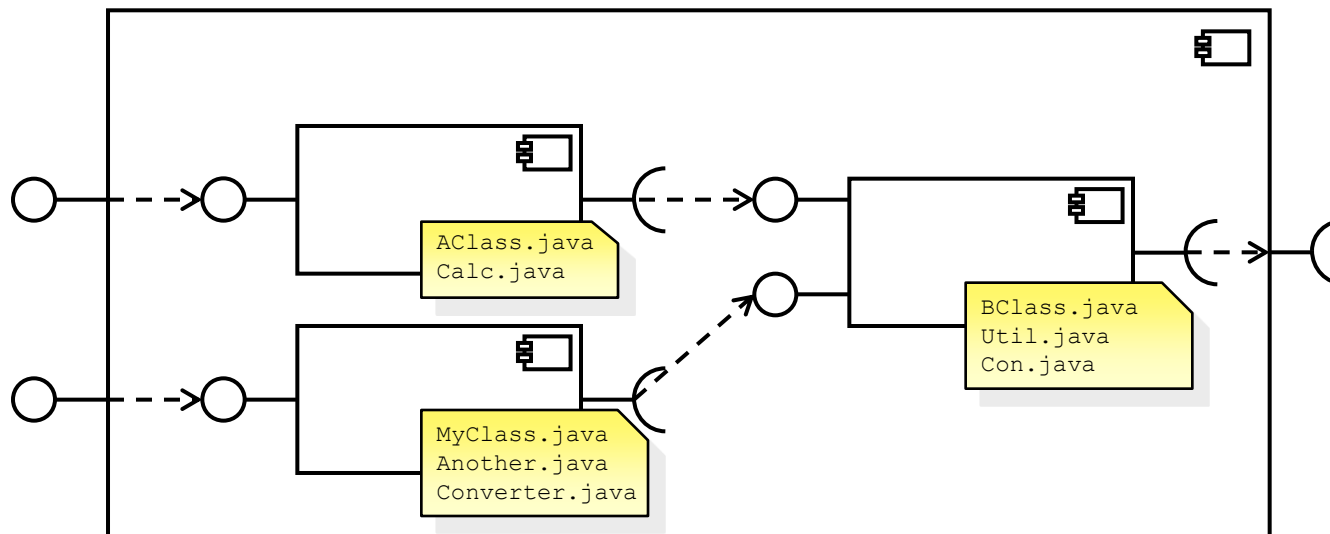

- Target Model:
Q-ImPrESS Software Architecture Model (SAM)

How SoMoX works

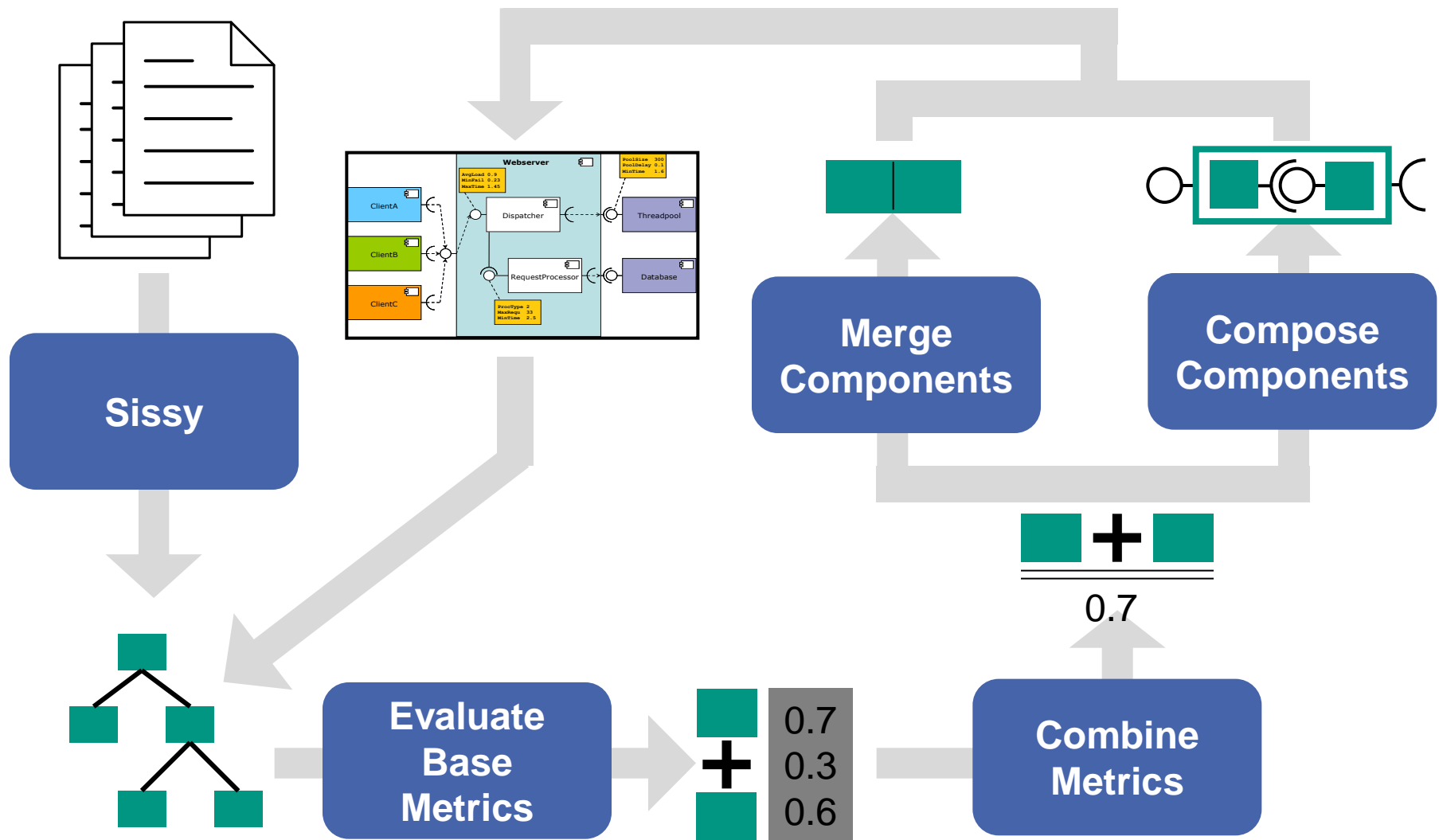

Composition

- Component candidates
 - Weakly connected components in the graph
 - Metrics evaluate pairs of component candidates

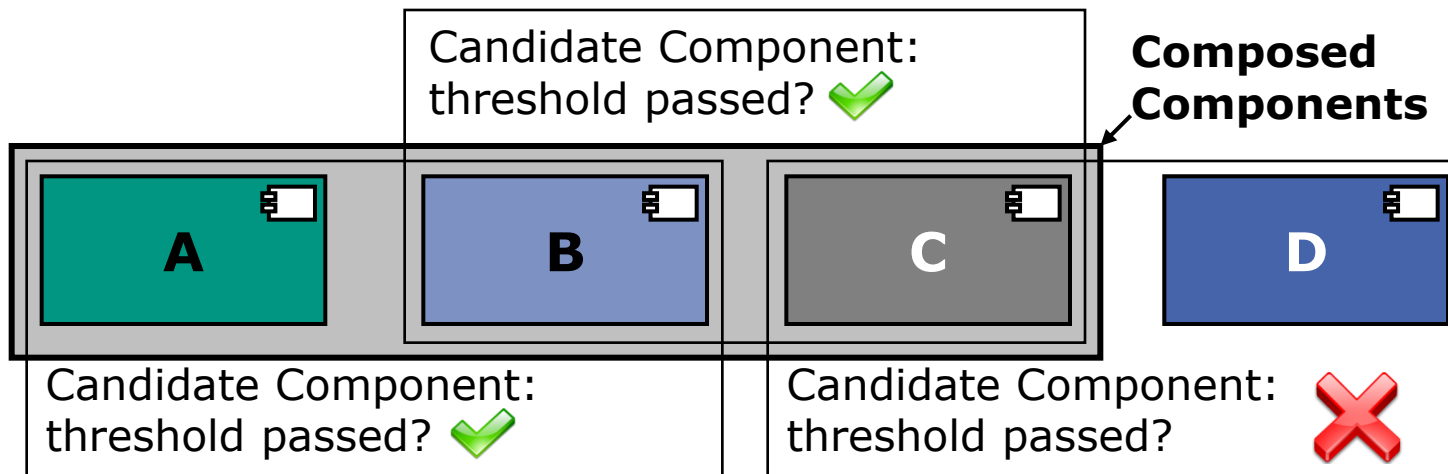

Combine Metrics

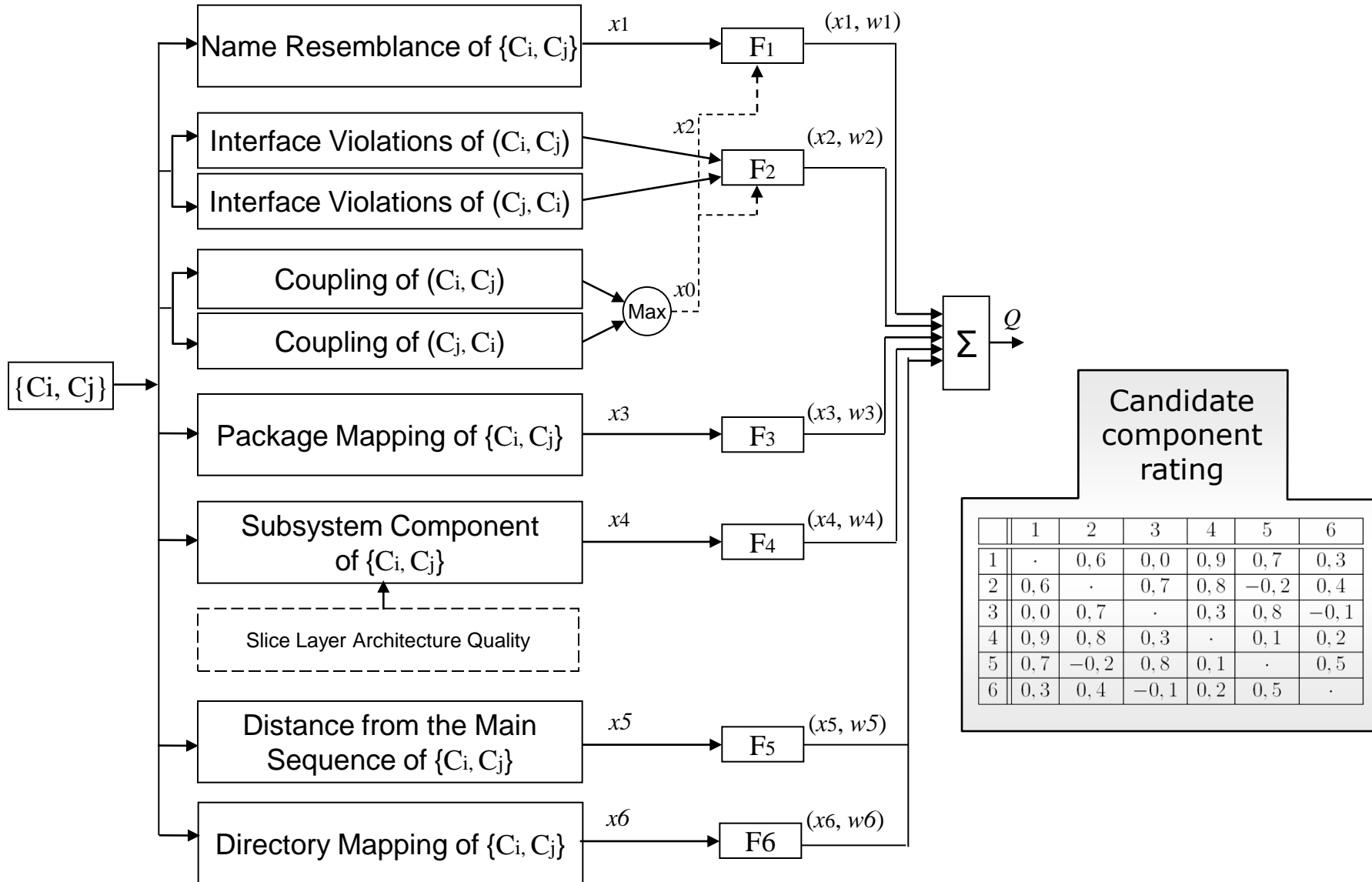

Live Demo



Customize SoMoX

Adaptable to your needs

- Configure weights
- Change structure of metrics
- Plug in new metrics, e.g.
 - EJB deployment descriptor support
 - Custom interface definition language

- Eclipse Technologies
 - Data models and metrics: EMF
 - Graphical editors: GMF

Further information



**Reconstructs a component-based
software architecture from a pile of files**

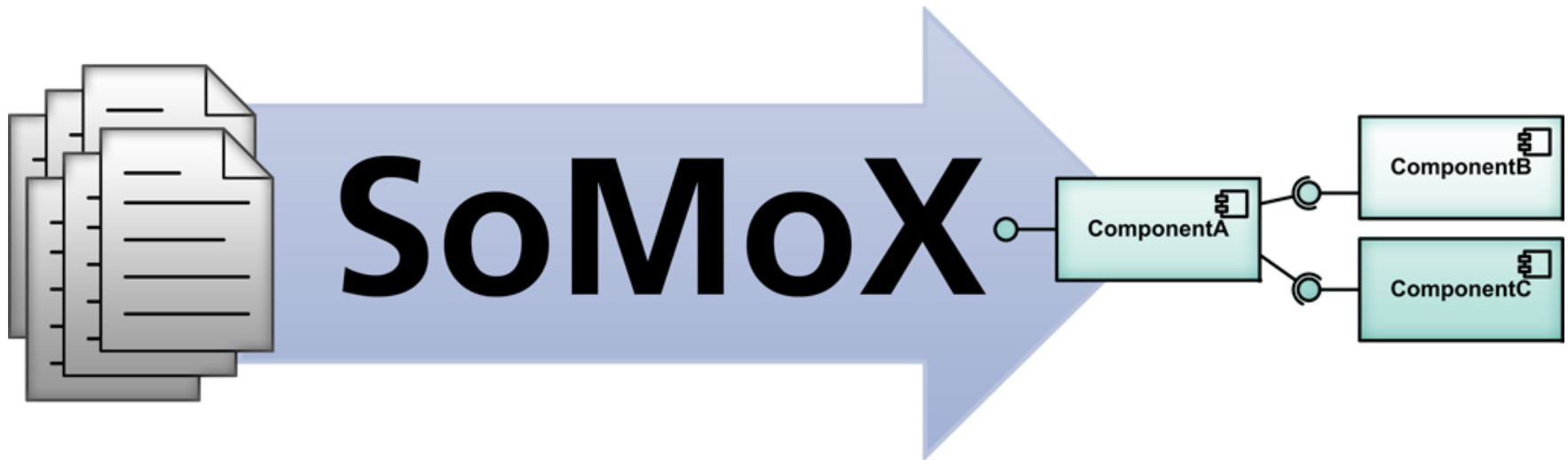

web: www.SoMoX.org

mail: krogmann@kit.edu