

Persisting Model Data

Metamodel Instances or Human-Readable Textual
Syntax?

Ericsson Modeling Days

2016 September 13



Outline

- Welcome and Introductions
- Definition of Terms
- MDA Flow
- Examples: Papyrus-RT and Papyrus-xtUML (BridgePoint)
- Underlying Persistence
- Advantages of Two Ways of Persisting
- Conclusions



Definition of Terms

- syntax
- semantics
- human-readable parsable textual concrete syntax
- grammar
- abstract syntax tree (AST)
- metamodel

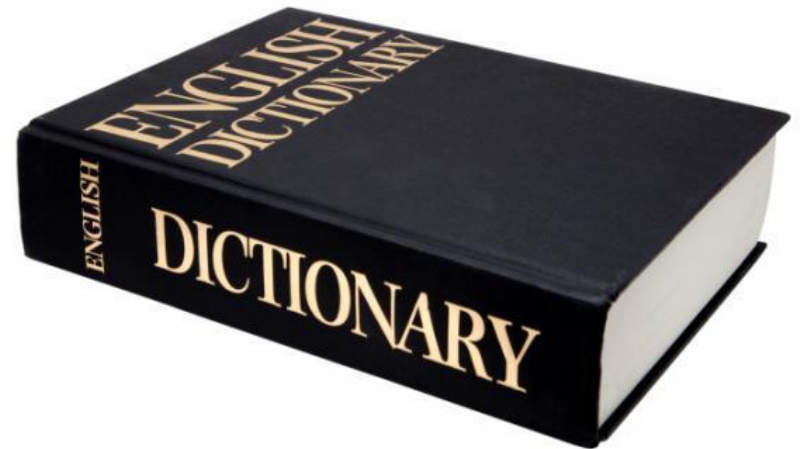

Definition of Terms

- **syntax** - physical shape and form of a language textual and/or graphical
 - semantics
 - human-readable parsable textual concrete syntax
 - grammar
 - abstract syntax tree (AST)
 - metamodel

Definition of Terms

- syntax
- **semantics** - *meaning* encoded, stored and communicated in a language
- human-readable parsable textual concrete syntax
- grammar
- abstract syntax tree (AST)
- metamodel

SEMANTICS

- ❖ Linguistic semantics is the study of meaning that is used for understanding human expression through language
- ❖ The study of meaning that focuses on the relation between *signifiers*, like words, phrases, signs, and symbols, and what they stand for, their denotata.

Definition of Terms

- syntax
- semantics
- **human-readable parsable textual concrete syntax** - text-based, regularly formed language that can be viewed, read, modified and stored as text by humans and by machines. Examples include C, Java, Python and Action Language (e.g. Alf, OAL, MASL)
- grammar
- abstract syntax tree (AST)
- metamodel

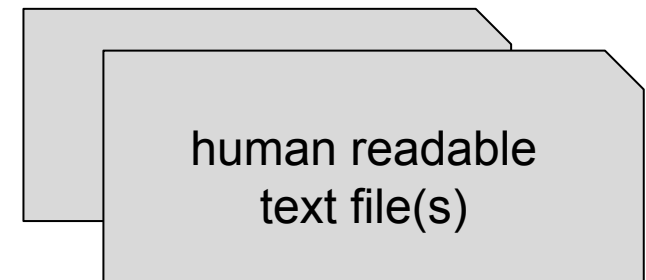

Definition of Terms

- syntax
- semantics
- human-readable parsable textual concrete syntax
- **grammar** - rules for parsing a textual language. A grammar mathematically encodes the rules that govern the syntax of a language. Tools that operate on grammars include antlr, Xtext, lex, yacc and bison.
- abstract syntax tree (AST)
- metamodel

The logo for Xtext, featuring the word "Xtext" in a bold, sans-serif font. The "x" is black, "t" is black, "e" is black, and the "t" at the end is black. The "x" is stylized with a blue-to-purple gradient, and the "t" at the end is also stylized with a blue-to-purple gradient.

Definition of Terms

- syntax
- semantics
- human-readable parsable textual concrete syntax
- grammar
- **AST (Abstract Syntax Tree)** - hierarchical structure capturing an intermediate form of a parsed language. Parsers parse text and store the interesting bits into a tree. The AST is more abstract (closer to the semantics) than the textual syntax but still largely influenced by the physical shape of the language.
- metamodel

Definition of Terms

- syntax
- semantics
- human-readable parsable textual concrete syntax
- grammar
- abstract syntax tree (AST)
- **metamodel** - Model of the language loaded into memory and inter-related often as Java or Ecore objects. Examples include UML2, xtUML and UML-RT.

AST \neq metamodel

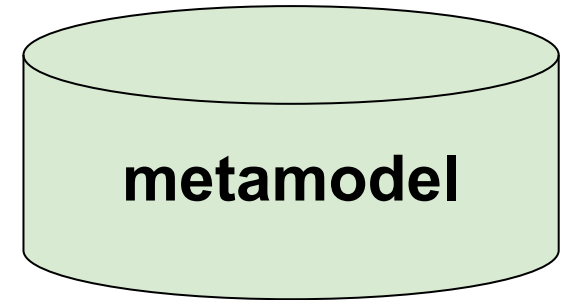

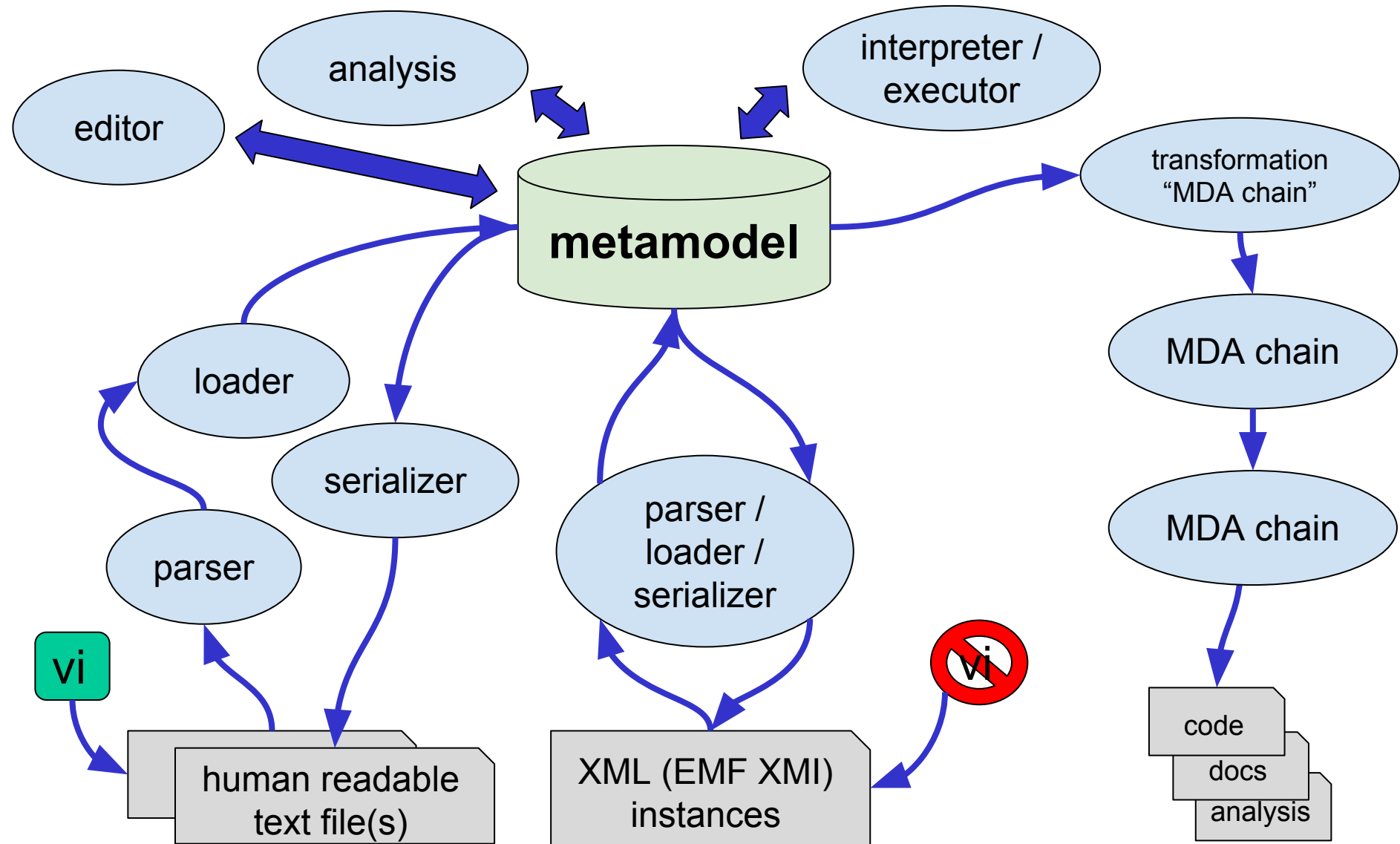

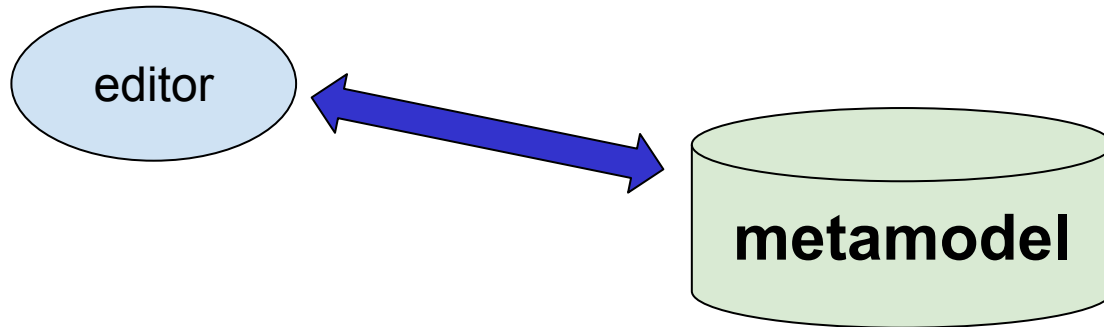

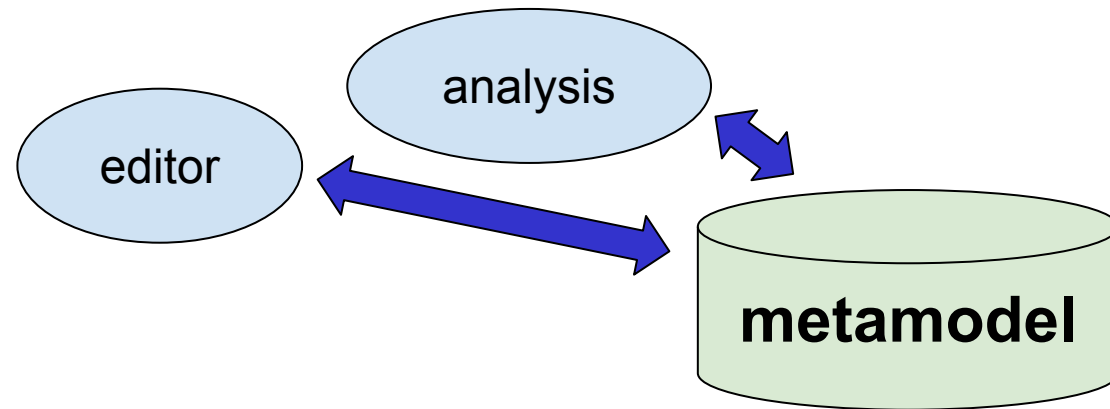

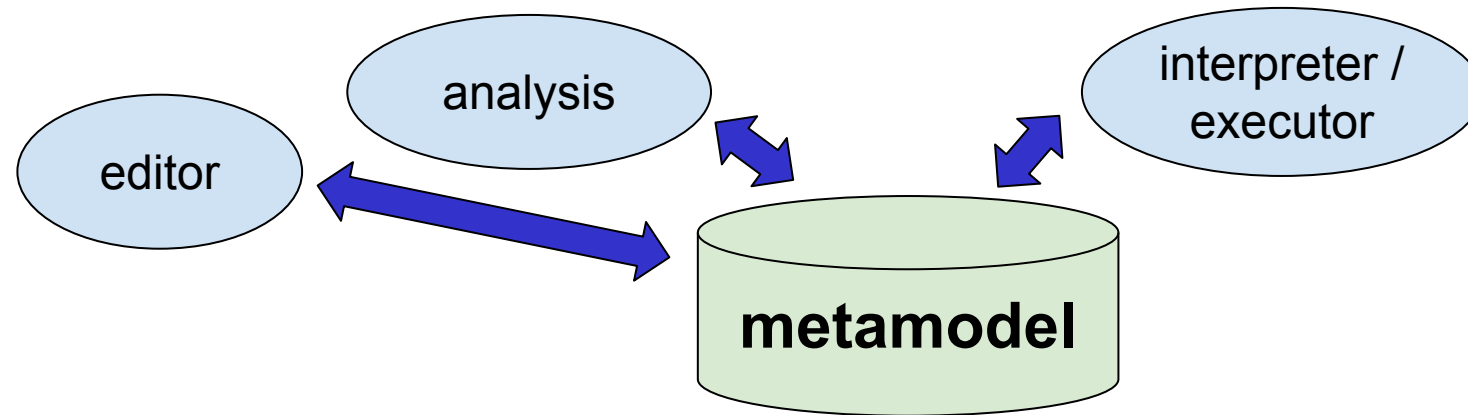

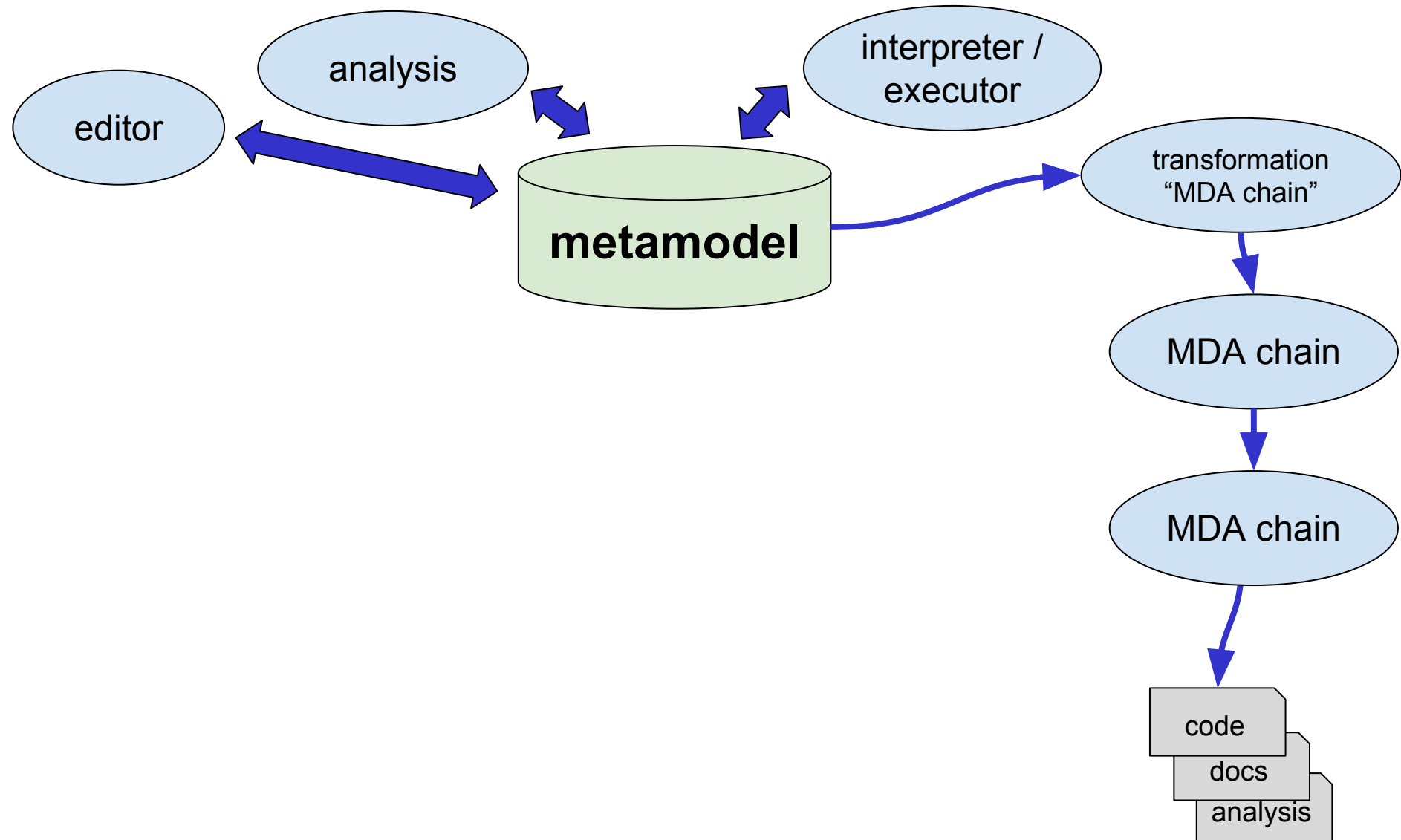

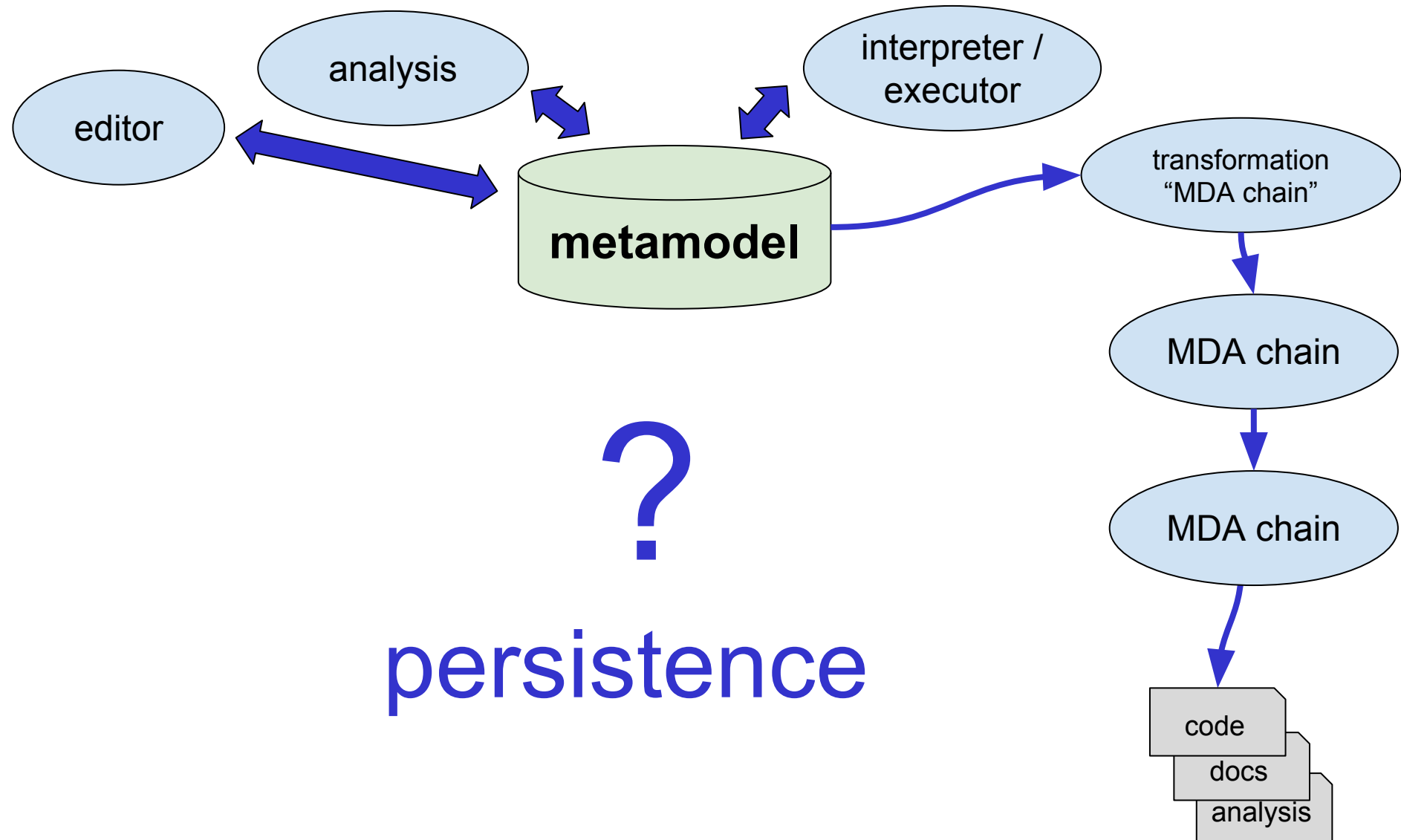

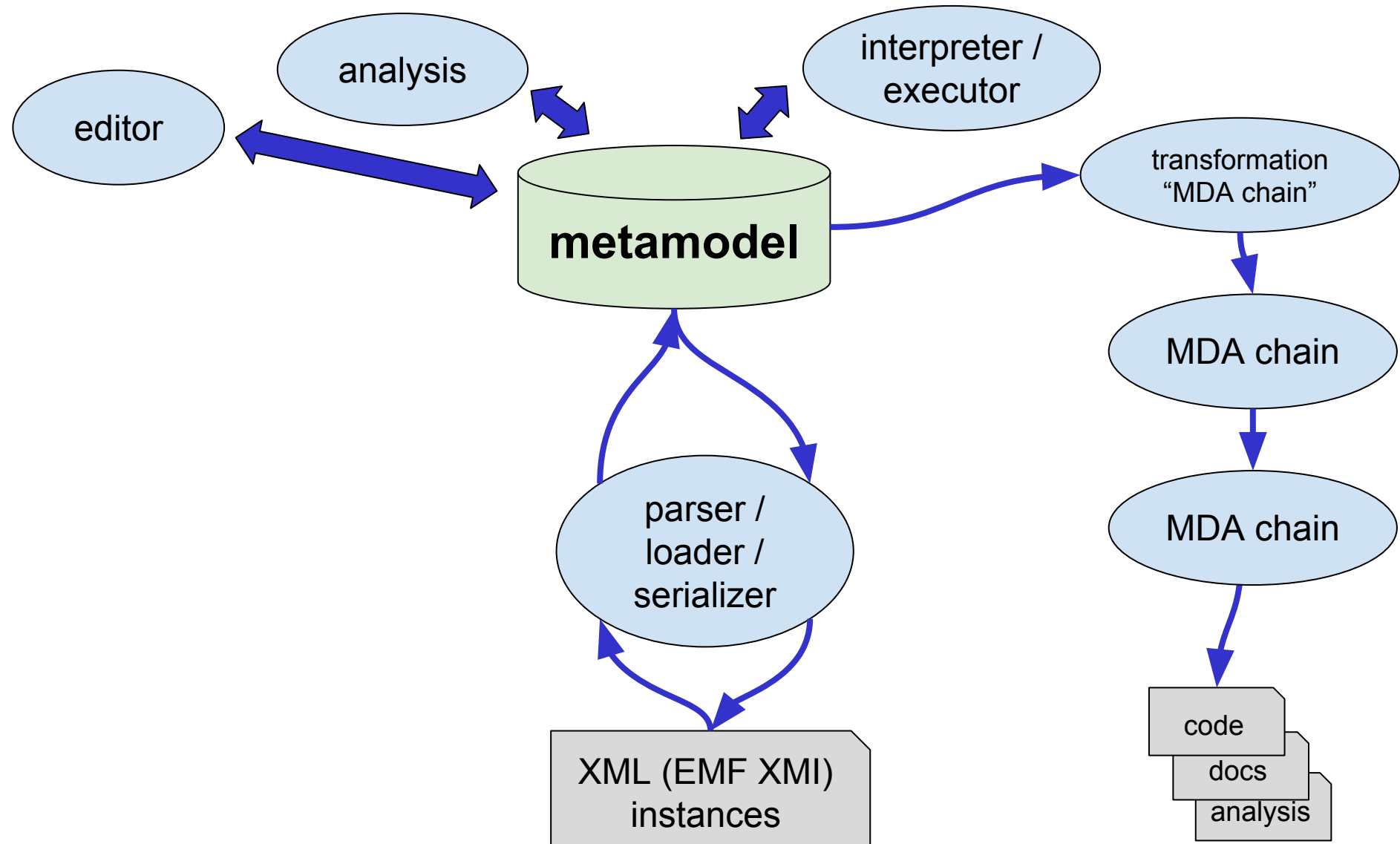

Example: Persisting UML2 Instances in Papyrus-RT

```
<xmi:XMI xmi:version="20131001" xmlns:xmi="http://www.omg.org/spec/XMI/20131001"
  <uml:Model xmi:id="_R_b1UD1vEeaoHtWsKsKbKg" name="pingpong">
    <packagedElement xmi:type="uml:Package" xmi:id="_6VghMD1vEeaoHtWsKsKbKg" name="pingpong">
      <packagedElement xmi:type="uml:Collaboration" xmi:id="_6QznYD1vEeaoHtWsKsKbKg" name="pingpong">
        <interfaceRealization xmi:type="uml:InterfaceRealization" xmi:id="_6Vq5tD1vEeaoHtWsKsKbKg" name="pingpong">
          <name xsi:nil="true"/>
        </interfaceRealization>
        <interfaceRealization xmi:type="uml:InterfaceRealization" xmi:id="_6V5ivD1vEeaoHtWsKsKbKg" name="pingpong">
          <name xsi:nil="true"/>
        </interfaceRealization>
      </packagedElement>
      <packagedElement xmi:type="uml:Interface" xmi:id="_6VlZsD1vEeaoHtWsKsKbKg" name="pingpong">
      <packagedElement xmi:type="uml:Interface" xmi:id="_6VujoD1vEeaoHtWsKsKbKg" name="pingpong">
      <packagedElement xmi:type="uml:Usage" xmi:id="_6VzcID1vEeaoHtWsKsKbKg" class="pingpong">
        <name xsi:nil="true"/>
      </packagedElement>
      <packagedElement xmi:type="uml:AnyReceiveEvent" xmi:id="_6V0DMD1vEeaoHtWsKsKbKg" name="pingpong">
      <packagedElement xmi:type="uml:Interface" xmi:id="_6V1RUD1vEeaoHtWsKsKbKg" name="pingpong">
      <packagedElement xmi:type="uml:Usage" xmi:id="_6V6w4D1vEeaoHtWsKsKbKg" class="pingpong">
        <name xsi:nil="true"/>
      </packagedElement>
    </packagedElement>
```

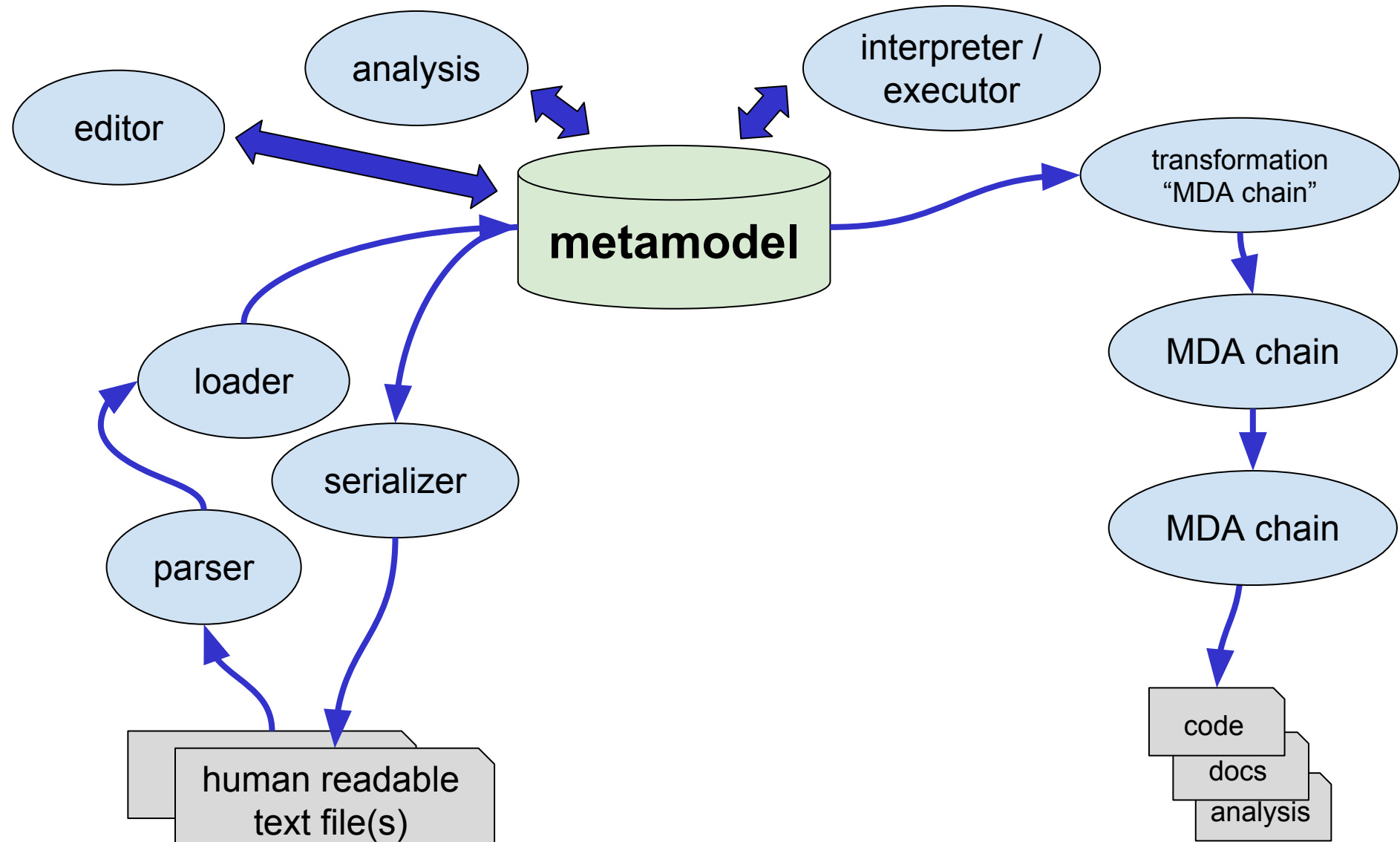

Example: Persisting Alf in Papyrus

```
class Order {  
  
    /*Attributes*/  
    public datePlaced: Date;  
    public lineItems: OrderLineItem[0..*];  
    public totalAmount : Money = (Money)0;  
  
    /*Operations*/  
    public addProduct(in product : Product, in quantity : Integer) {  
        lineItem = new OrderLineItem(product, quantity);  
        this.lineItems->add(lineItem);  
        this.totalAmount = this.totalAmount + lineItem.getAmount();  
    }  
}
```

Persisting UML-RT in Papyrus-RT [experimental]

```
capsule Top
{
    part pinger : Pinger [ 1 ] ;
    part ponger : Ponger [ 1 ] ;
    connect pinger : pingPort to ponger : pongPort ;
}
capsule Pinger
{
    port pingPort : PingPongProtocol [ 1 ] ;
    statemachine
    {
        initial i0 ;
        state Playing
        {
            entry action {|#
                log.log(LCAPINST, "(enter Playing) sending ping");
                pingPort.ping().send();
                int n = 1;
                int z = 2;
            #|}
        }
    }
}
```

Persisting MASL in Papyrus-xtUML (BridgePoint) [experimental]

```
relationship R4 is Session_Specification conditionally defines_rules_for many Session,  
Session unconditionally rules_are_defined_by one Session_Specification;  
  
relationship R5 is Session unconditionally has_allowed many Operation,  
Operation unconditionally has_been_allowed_for many Session  
using Session_Operation;  
  
object Group is  
  group_id : preferred unique integer;  
  group_name : string;  
  
end object;  
pragma id (3);  
pragma key_letter ("G");  
  
object Group_For_Session is  
  group_id : preferred referential (R2.is_member_of.Group.group_id) integer;  
  session_id : preferred referential (R2.current_members_are.Session.session_id) integer;  
  
end object;
```

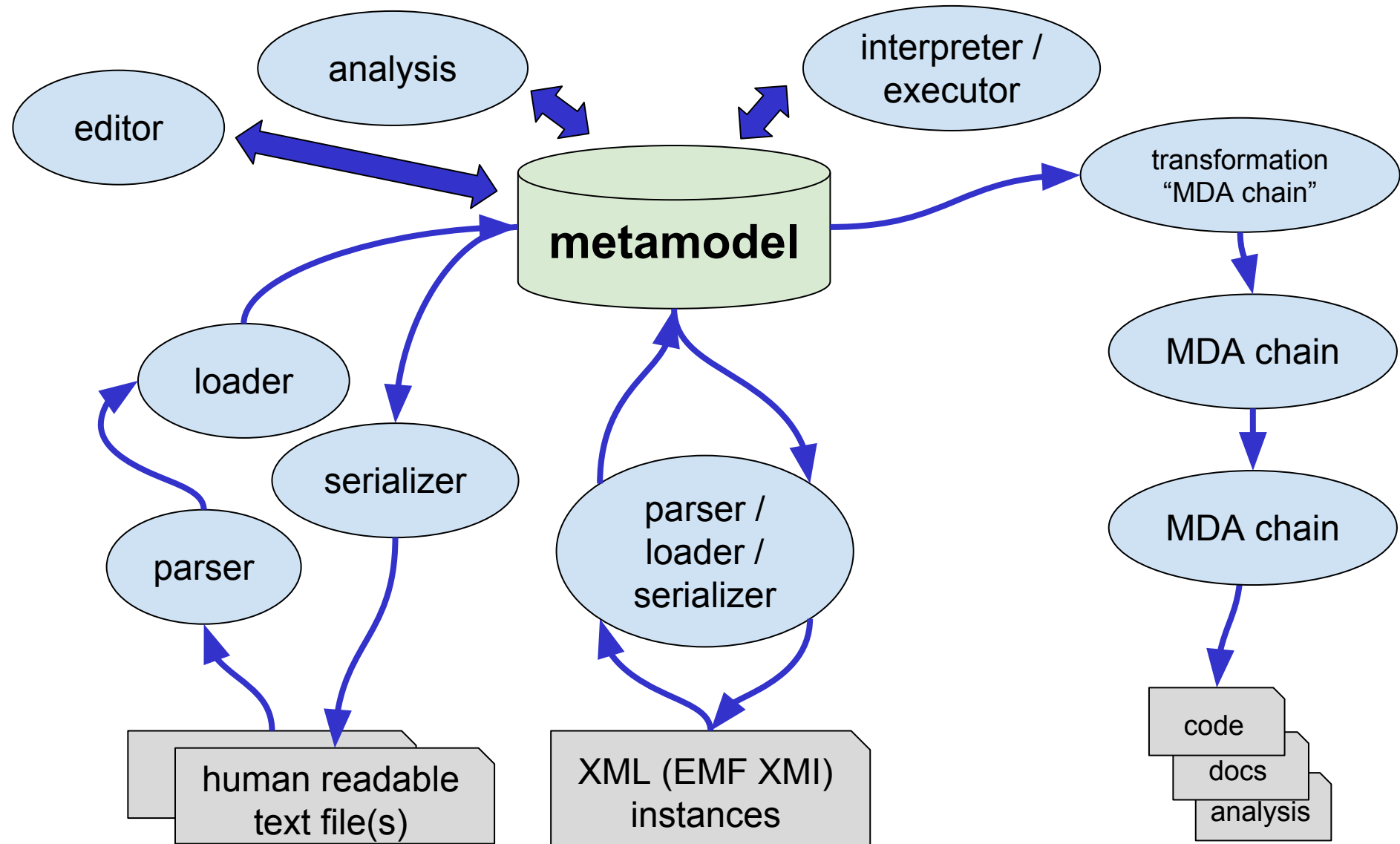

Metamodel Fragment

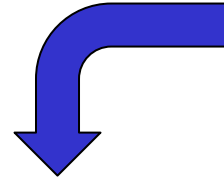

Input Model

```

object PUMP is
  matrix is
    Ready_For_Use (
      Gun_Removed      => Pumping,
      Trigger_Depressed => Ignore,
      Trigger_Released => Ignore,
      Customer_Finished => Ignore);
    Pumping (
      Gun_Removed      => Ignore,
      Trigger_Depressed => Ignore,
      Trigger_Released => Pumping_Paused,
      Customer_Finished => Ignore);
    Fuel_Delivery_Complete (
      Gun_Removed      => Ignore,
      Trigger_Depressed => Ignore,
      Trigger_Released => Ignore,
      Customer_Finished => Ready_For_Use);
  end transition;
end object;
  
```

Grammar and AST have:

- Matrix
- TransitionTable
- TransitionRow

AST ≠ metamodel

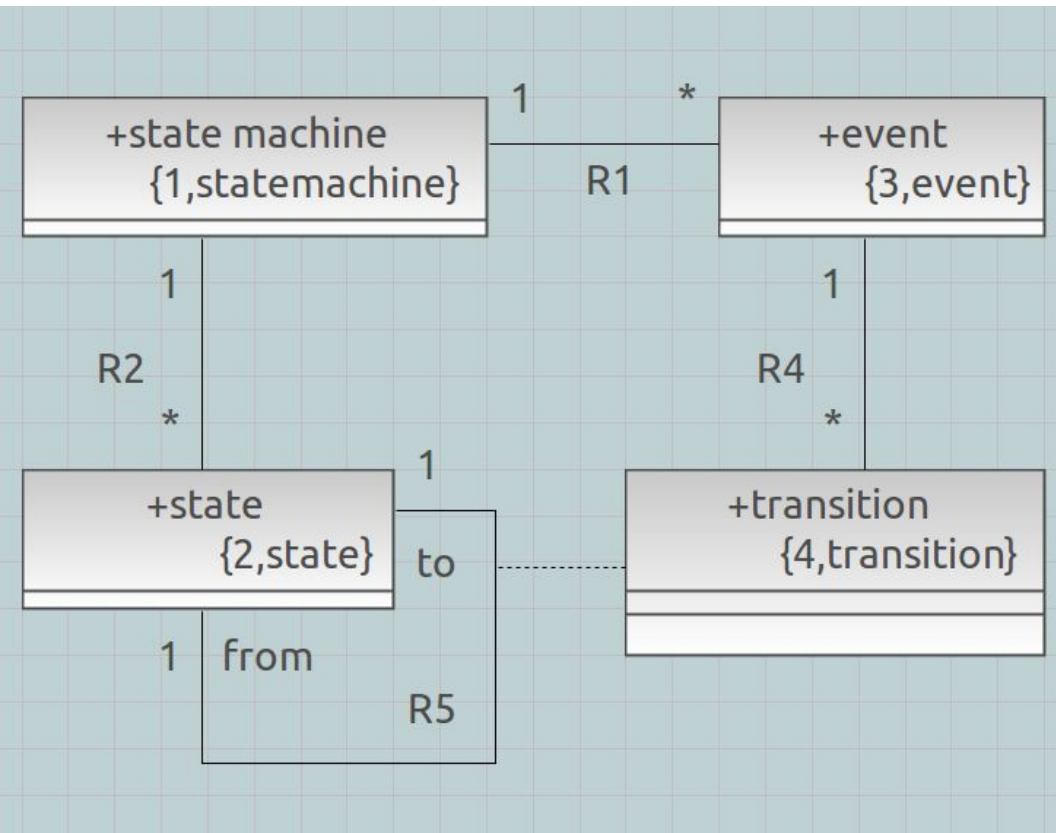

Advantages of XMI (Instance-Based Persistence)

UML2/EMF/XMI and xtUML/SQL

- Already works
- Simple parsing at the XML level
- Same for all EMF-based models and all UML2-models
- Does not have to care for semantics
- Graphics (Layout) can be persisted as instances
- Separation of concerns: Persistence layer vs. Editing
- ID-based referencing (more robust against dangling refs)
- Not editable by any editor, avoids risk of destruction
- Can still be mixed with partial textual representations

Advantages of Human-Readable Parsable Textual Syntax

MASL, textual UML-RT, Alf

- Human readable!
- Editable (by any text editor)
- Better Searchable without deserializing (and sed/grep/awk-able)
- Textual Cut/Copy/Paste
- Textual Diff/Merge is possible
- Natural scoping
- Model corruption may be more easily addressed
- Compact persistence
- Consistency between structural and activity persistence

Conclusion

Human-readable parsable textual concrete syntax offers benefits but brings costs.

XMI is mature, flexible and more straight-forward.

Backup Slides

Persisting xtUML Instances in Papyrus-xtUML (BridgePoint)

```
-- BP 7.1.6 content: ModelClass syschar: 3 persistence-version: 7.1.6

INSERT INTO O_OBJ
VALUES ("66920350-b77d-4876-9b05-0c545b5437ae",
'TrackPoint',
3,
'TrackPoint',
'',
"00000000-0000-0000-0000-000000000000");
INSERT INTO O_NBATTR
VALUES ("7080b4f6-ebf6-47fe-be82-a1c2cf39143c",
"66920350-b77d-4876-9b05-0c545b5437ae");
INSERT INTO O_BATTR
VALUES ("7080b4f6-ebf6-47fe-be82-a1c2cf39143c",
"66920350-b77d-4876-9b05-0c545b5437ae");
INSERT INTO O_ATTR
VALUES ("7080b4f6-ebf6-47fe-be82-a1c2cf39143c",
"66920350-b77d-4876-9b05-0c545b5437ae",
"00000000-0000-0000-0000-000000000000",
'time',
```

Example: Papyrus

- Papyrus
 - Built on UML2 and GMF
 - GMF-based diagrams for UML2
- GMF
 - FW for building graphical modeling editors
 - For EMF-based modeling languages
- UML2
 - EMF-based implementation of UML2
- UML2/GMF models
 - Plain EMF models
 - Any EMF technology works ~

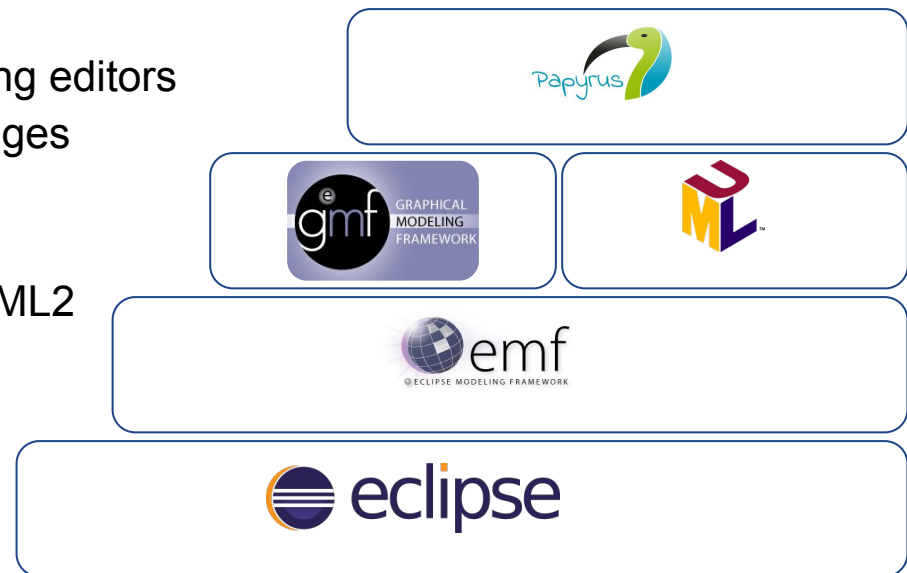

Example: Papyrus-RT

- Papyrus-RT
 - UML2-based profile (~metamodel)
 - Extension of Papyrus' diagram editors
 - Customization of tools (palette, properties, ...)
 - Code generators, ...
- Papyrus/UML2-based profiles
 - Ecore metamodel generation (static)
 - EMF metamodel API generation

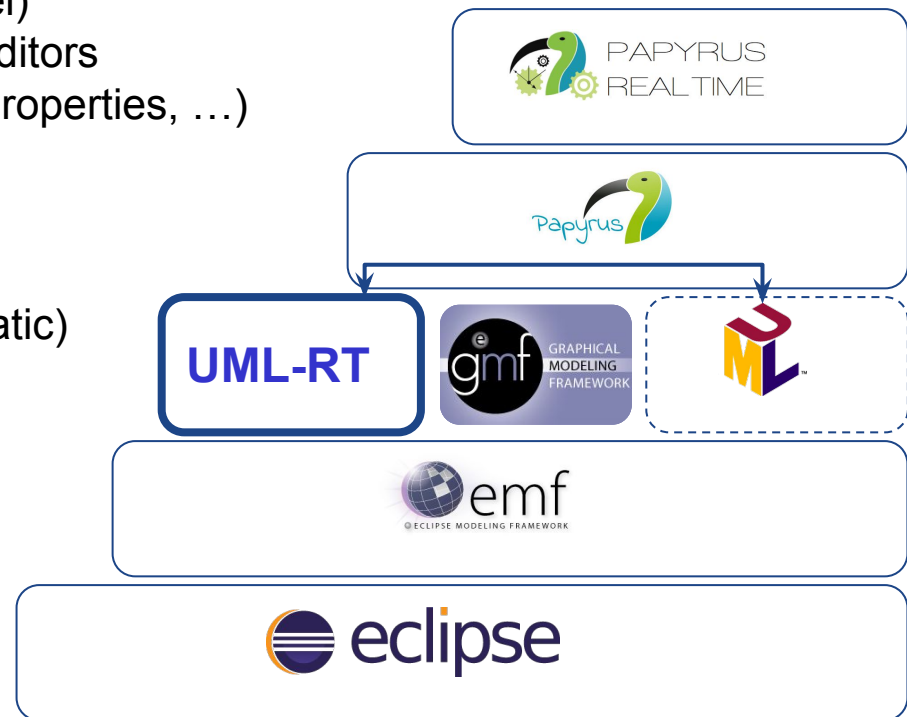

Example: Papyrus-xtUML (BridgePoint)

- Bridgepoint
 - GEF-based Modeling editors
 - Model compilers (rely on xtUML metamodel)
 - Model interpreters (rely on xtUML metamodel)
- xtUML
 - Metamodel of the language
 - API to interact with model
 - Implementation of the xtUML API
- SQL
 - Format to persist models
- GEF
 - Technology to build modeling editors

